

Flat Pattern view
SCALE: 1:2

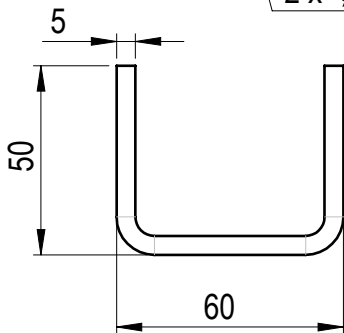
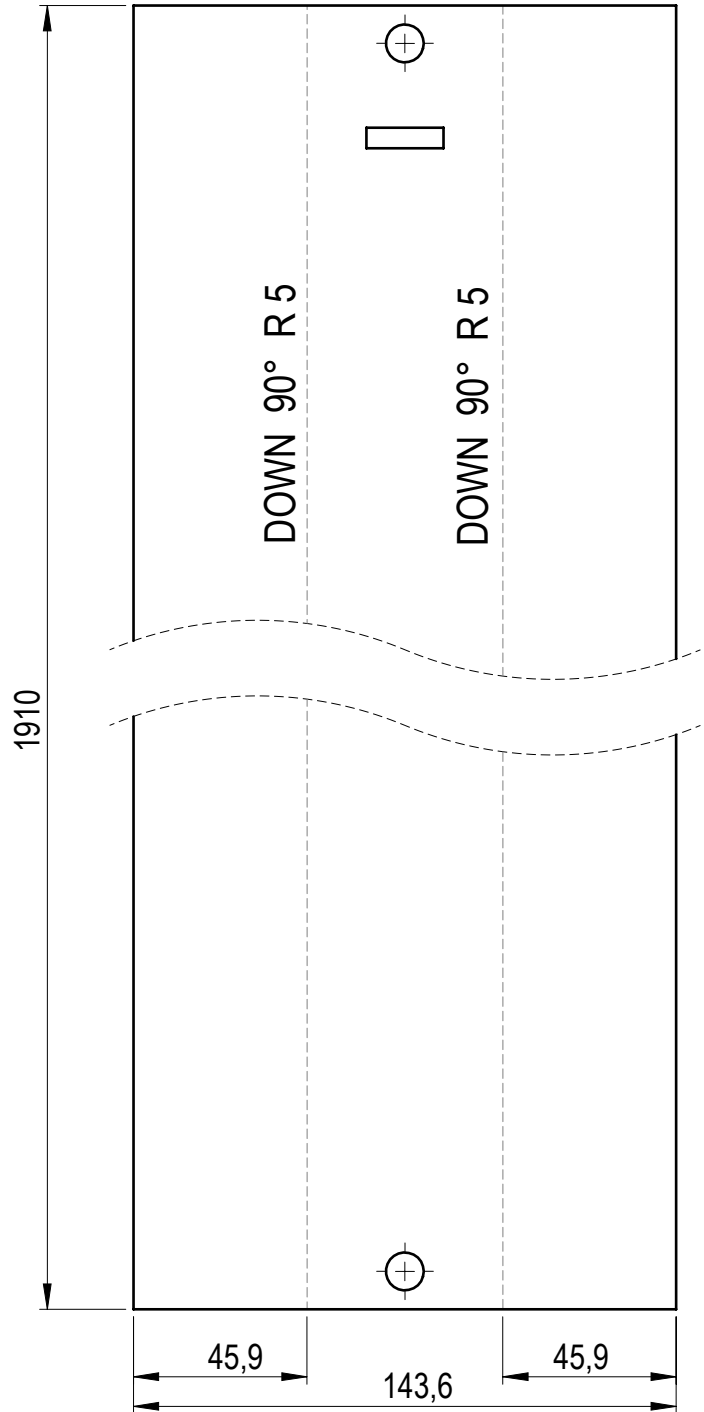
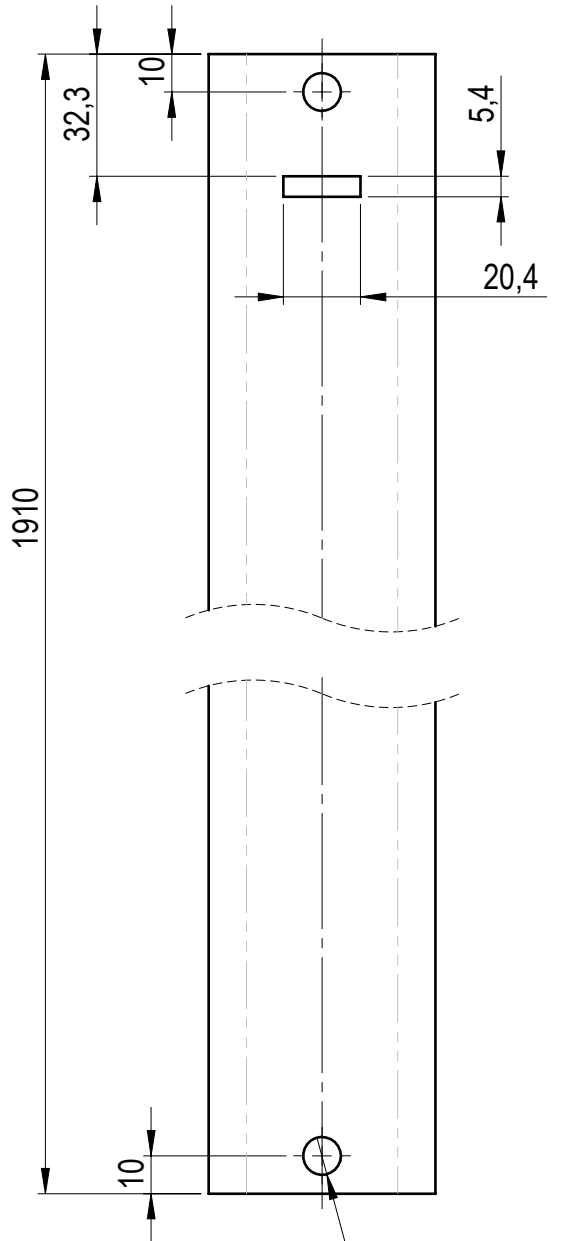

Other dimensions from DXF file

SHEET METAL INFORMATION	
Length, mm	1910
Width, mm	143.6
Thickness, mm	5
Inside Bend Radius, mm	5
K-Factor	0.5
No. of Bends	2

	MATERIAL	S355J2	WEIGHT	10.684 Kg	DEBURR AND BREAK SHARP EDGES	DO NOT SCALE DRAWING	REVISION	DATE	23.05.2025	
	SURFACE PROTECTION	-	MACHINING	ISO 2768 mK	THERMAL CUTTING	ISO 9013 221	WELDING	ISO 13920 BF	SCALE	1:2
NAME	SIGNATURE	PART NO.	105-09206-01							
Designed by	D. Dislers		Bent body plate 3						SHEET 1/1	
Drawn by	D. Dislers									
Technical ref.										